



# BIODOSE

A Sustainable Solutions Company



# The Companies Core Values & Beliefs

- Biosecurity's Solution's purpose is to source and implement technologies that offer specific attributes; Sustainability; Little or No Environmental Impact; Long Service Life, Value for Money and Reduced Carbon Footprint.
- Biosecurity Solution's and Biodose Limited are constantly seeking out the latest disruptive technologies to deliver superior, sustainable cleaning solutions to our customers throughout the world.
- These technologies incorporate efficiencies in packaging, shipping, storage and dispensing. Our aim is to help you and your clients to substantially reduce your carbon footprint, at the same time providing a safer environment to work in.
- Our Partners include:





**BIODOSE SOLID BLOCK  
TECHNOLOGY**

# Solid Block Technology

- Designed to remove Fats, Oil & Grease from drains
- Operates a 360 degree clean ensuring no F.O.G. is left in the line
- Durable unit with small footprint
- Can be used with Pucks or Block
- Quarterly service schedule
- Cartridge/cage system for easy chemical replenishment
- Cheaper & More Effective than liquid systems



## PACK SIZES

- 1.5kg block
- 5kg lift station block
- 100gm Powder sachets

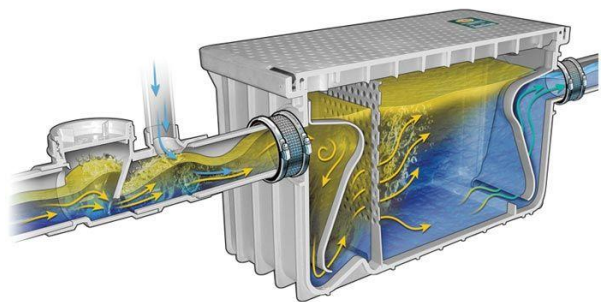

A 360° bacteria based cleaning solution  
for drains and grease traps



**BIODOSE AUTOMATIC GREASE  
INTERCEPTOR**

# Automatic Grease Interceptor

- Patented system
- PVC molding
- Built-in water trap to stop food debris, isolate bacteria and bad odours
- Filter basket volume 690ml
- Easy cleaning port
- Suitable for  $\phi 110$  sink under water outlet
- Increase the oil content of oil separator
- Never rust, no corrosion
- 2-year warranty

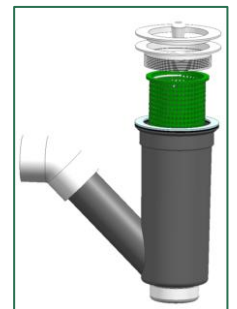
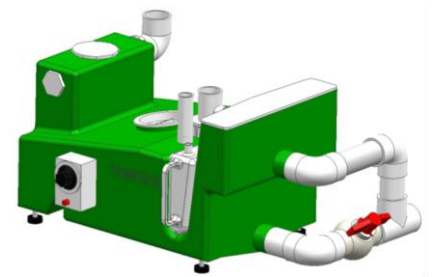
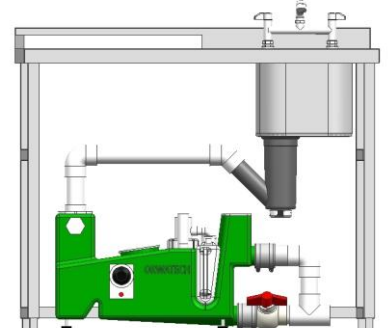



# BIODOSE PRO-PACS

# Cleaning Pac's for Professionals



- Up to 80% reduction in Carbon Footprint
- Fully dissolvable packs (3gm-22gm)
- Large reduction in packaging
- Less shipping and transport
- Less impact on the environment
- Less storage space required by the customer

**1 pallet contains 125 Cases of  
6 x 750ml Trigger Sprays  
750 x 750ml Trigger Sprays  
(563 Litres)  
562.5Kg**



**1 Bag contains 100 x 3ml  
ProPacs  
8 bags = 800 x 750ml Trigger  
Sprays  
(600 Litres)  
2.5 Kg**



# Cleaning Pac's for Professionals

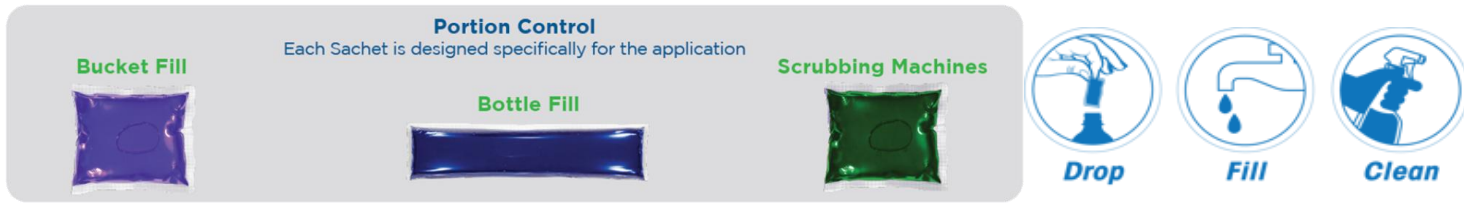

- Each dissolvable pac is designed specifically for the application
- Portion control allows for inventory and process management control
- Dosage rate and accuracy is measurable and consistent
- Eco Friendly
- No dispenser installation
- No maintenance
- No single use plastic
- No Chemical drums
- Portion-controlled cleaning & Tendering



# Cleaning Pac's for Professionals

## Environmental Impact

- **CLEANING & DISINFECTING PAC'S**
- Safer-choice certified formulations
- Biodegradable and phosphate free
- Up to 80% reduction in Carbon Footprint
- Fully dilutable
- Zero waste product
- No single use plastic
- Reduces land fill waste
- Environmentally friendly and full compostable



- **HAND WASH**

- Coconut scent
- 750-1000ml bulk fill dispenser
- 350ml / 500ml foaming bottles
- Small 7ml-20ml packs



Economical and competitive





# BIODOSE SAN-AIR PURIFICATION

# San-Air Air Purification

- SAN AIR is a 100% natural gel that evaporates into the indoor air, killing germs, mould and bacteria on contact
- SAN-AIR is PROVEN to:
  - Kill mould, Bacteria, and Viruses in the air and on surfaces
  - Prevent re-growth
  - Increase infection control methods
  - Provide 24/7 protection
  - Be effective against Coronavirus
  - Reduce cross contamination

## AIR PURIFICATION



V3R Air Purifier  
Reactive Gel 75g



V3R Split System  
Reactive Gel 15g



V3R Air Handler Reactive  
Gel 500g / 1kg

## MOULD REMEDIATION



Mould Gone Reactive  
Gel 75g



V3R Surface Mould  
Remover 500ml, 1Ltr,  
5Ltr



DIY Bateria Test Strips

## SPECIALITY PRODUCTS



Caravan, Boat and  
Storage Reactive Gel  
(Targets Sea Mould)



Pet Odour Eliminator Gel  
(Kills E-Coli and Odour  
Control)



MozzyNo Mosquito  
Insect Repellent Gel  
(Kills micro-bacteria on  
skin, repelling bugs)

## PERSONAL SPACE SANITISATION



V3R Personal Space  
Sanitiser Pen 10ml



V3R Waterless Hand  
wash 50ml, 500ml, 1Ltr,  
5Ltr



Car Air Purifier  
Reactive Gel 75g



# San-Air Air Purification Independent Testing

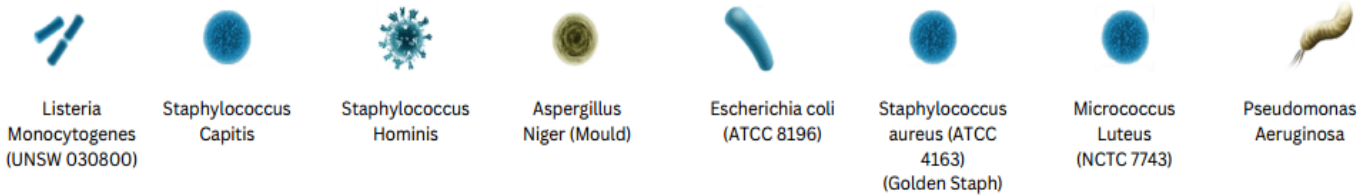

**EUROFINS | AMS**

SAN-AIR Liquid passed the TGA Disinfectant Test, Option C

SAN-AIR liquid is classified as a household & commercial grade disinfectant.

The only proven disinfectant that contains 100% natural actives and has no harsh chemicals.

UNSW Global Australia		
Test Organism	SAN-AIR GEL & LIQUID KILL-RATES (%) Contact Time	
	5 minutes	30 minutes
Escherichia coli (ATCC 8196)	99.999	99.999
Staphylococcus aureus (ATCC 4163)	99.954	99.978
Listeria monocytogenes (UNSW 030800)	99.999	99.999
Micrococcus luteus (NCTC 7743)	76.390	95.921

**CHEMSIL**

SAN-AIR kills 99% for fungicidal activity and 99% for sporicidal activity.

In accordance with TGA protocols, SAN-AIR was tested against representative mould species to determine efficacy against fungus and fungal spores (which are more difficult to kill than fungus).

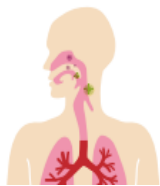

**SAN-AIR is the only safe solution for the ongoing elimination of airborne contaminants, reducing the risk of AIRBORNE TRANSMITTED INFECTIONS**

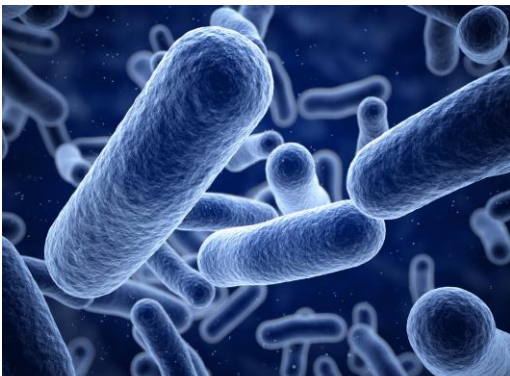

**SAN-AIR – A Scientific breakthrough in Organic Chemistry. Independently tested, validated and Proven**





**BIODOSE URINAL DRAIN  
TREATMENT**

# Waterless Trap Seal for Floor Drains

- Prevents odours emitting from your drain
- Stops pests from entering your premises
- Prevents the spread of viruses and bacteria
- Protects from sewer gases
- Allows a high flow of water down the drain
- Available in various sizes

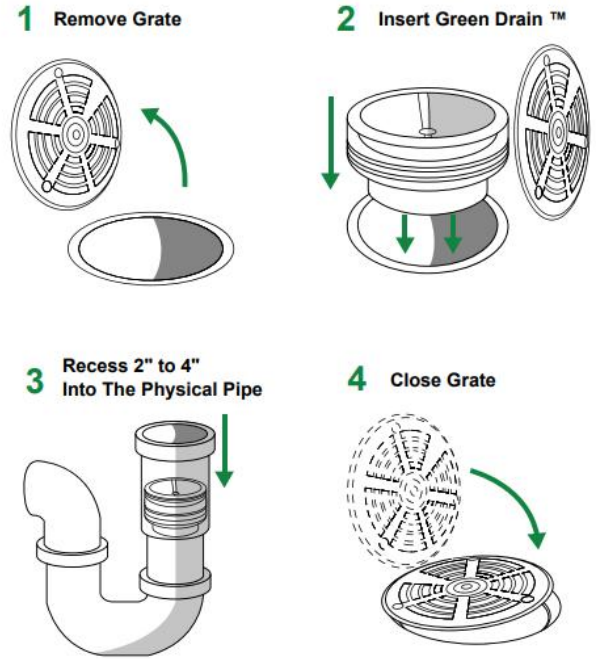

**Easy to install, simply measure the inner diameter of your drain and match to the appropriate GD seal**  
**Fit as per instructions**

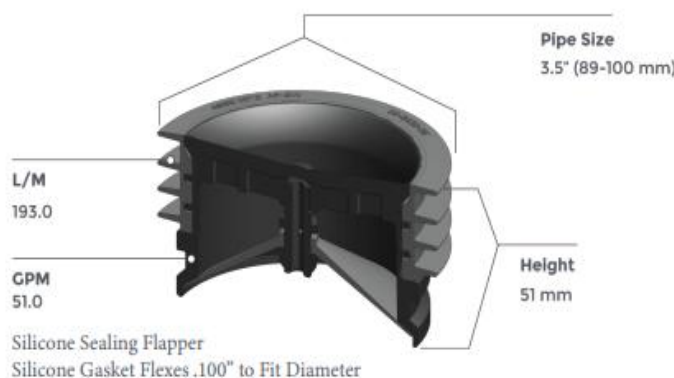

# Waterless Trap Seal for Floor Drains

- Large urinal drain illustrated GD4 (95MM-104MM)
- Replaceable puck
- Large enough to replace a waterless cartridge system
- Twist to open the cartridge and replenish the urinal puck



Cartridge



Trap Seal





**BIOSECURITY**  
SOLUTIONS

# GUARD-PRO CLEANER DISINFECTANTS

# Guard-Pro Protec+ Cleaner Disinfectants



## GP2

PROTEC+  
247  
UNSCENTED

- Disinfectant with sustained microbial activity giving peace of mind around the clock with Active Release Technology (ART)
- Effective up to 99.999% against harmful pathogens.
- Ideal for use on all surfaces & materials.
- Effective against Bacteria, Viruses, Spores, Mould & Fungi, including Coronavirus, Norovirus and Flu.
- Tested and approved to EN1276, EN1650, EN13697, EN13727, EN14561, EN14562, EN14476.



## GP2.1

PROTEC+  
247  
LEMON  
SCENTED

- Lemon scented Disinfectant with sustained microbial activity giving peace of mind around the clock with Active Release Technology (ART)
- Effective up to 99.999% against harmful pathogens.
- Ideal for use on all surfaces & materials.
- Effective against Bacteria, Viruses, Spores, Mould & Fungi, including Coronavirus, Norovirus and Flu.
- Tested and approved to EN1276, EN1650, EN13697, EN13727, EN14561, EN14562, EN14476.



## GP1

PROTEC+  
PLUS  
UNSCENTED

- Effective up to 99.999% against harmful pathogens
- Ideal for use on all surfaces & materials
- Effective against Bacteria, Viruses, Spores, Mould & Fungi, including Coronavirus, Norovirus & Flu
- Non-irritant, non-flammable
- Tested & approved to EN1276, EN1650, EN13697, EN13727, EN14561, EN14562, EN14776



# Guard-Pro Protec+ Cleaner Disinfectants



## GP1.1

PROTEC+  
PLUS  
UNSCENTED

- Effective up to 99.999% against harmful infections
- Effective against Bacteria, Viruses, Spores, Mould & Fungi, including Coronavirus, Norovirus & Flu
- Non-irritant, non-flammable
- Tested and approved to EN1276, EN1650, EN13697, EN13727, EN14561, EN14562, EN14776



## KG2

MULTI-  
SURFACE  
CLEANER  
&  
DISINFECTANT

- Kitch disinfectant effective up to 99.999% against harmful infections
- Effective against Bacteria, Viruses, Spores, Mould & Fungi, including Coronavirus, Norovirus & Flu
- Non-irritant, non-flammable
- Tested and approved to EN1276, EN1650, EN13697, EN13727, EN14561, EN14562, EN14776



## GP4

AERIAL  
DISINFECTANT FOR  
USE IN ALL MARKET  
SECTORS

- Effective up to 99.999% against harmful pathogens
- Ideal for use on all surfaces & materials
- Effective against Bacteria, Viruses, Spores, Mould & Fungi, including Coronavirus, Norovirus & Flu
- Non-irritant, non-flammable
- Tested & approved to EN1276, EN1650, EN13697, EN13727, EN14561, EN14562, EN14776



# GuanoFix Avian Disinfectant



## BENEFITS

- A Biocide used to kill disease related bacteria, viruses, spores and protozoa associated with birds and avian environments.
- A concentrated disinfectant for use in areas of bird activity.
- Prevents transmittable bird diseases including Avian Influenza, Avian Tuberculosis, Erysipelas, Ornithosis, Psittacosis, Cryptococcosis, Histoplasmosis, Salmonellosis, Cryptosporidiosis, Campylobacteriosis, and Escherichiosis.



## CONTACT:-

E: [sales@biosecuritysolutions.uk](mailto:sales@biosecuritysolutions.uk)

T: +44 (0)333 577 0039



**BIOSECURITY**  
SOLUTIONS

# HANDLE HYGIENE WASHROOM DISINFECTION

# Handle Hygiene Washroom Disinfection

- Handle Hygiene washroom disinfection has been specifically designed to prevent cross contamination in the washroom, providing a clean hands regime throughout the workplace.
- The system's efficacy has been scientifically proven in a peer reviewed study conducted in a major hospital in Dublin and published in a leading medical journal - "Journal of Hospital Infection."
- Reducing Cross Contamination in the workplace environment
- Providing a safer working environment for the workforce
- Providing a safer environment for your customers
- Reducing deaths from transferable pathogens
- Reducing absenteeism (average daily cost in excess of £230 pp/ per day in the UK)
- Promoting a healthy workplace
- Reducing cost in the workforce
- Reducing waiting lists in the NHS
- The system is fully automated, requiring no batteries or power supply, and instantly operates every time the door is used.





To deliver safe, sustainable products. Eliminate waste, reduce businesses carbon footprints and plastics from ending up in landfills and oceans



**BIO DOSE**  
A SUSTAINABLE SOLUTIONS COMPANY

